

R420 GASOLINE ENGINE 汽油机

FIG.1 HEAD SUBASSEMBLY, CYLINDER / PLUG,SPARK (E04)

图 1 : 气缸头部件/火花塞 (E04)

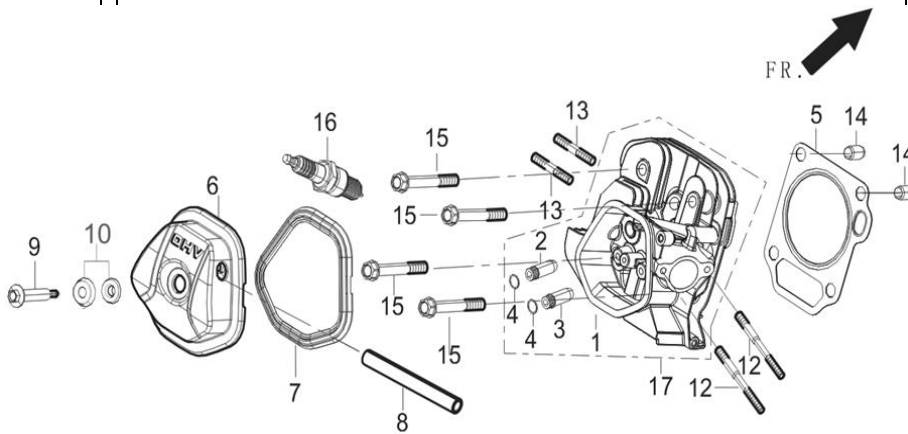

WORK HOURS 工时

5、 GASKET, CYLINDER HEAD.....	0.5H
6、 COVER SUBASSEMBLY, CYLINDER HEAD.....	0.1H
7、 GASKET, CYLINDER HEAD COVER.....	0.1H
16、 PLUG, SPARK.....	0.1H
17、 HEAD SUBASSEMBLY, CYLINDER.....	0.9H

REF. NO. 序号	PART NO 物料代码	CHINSES 中文名	DESCRIPTION 英文名	Q'TY 数量	包装数	备注
E04-5	12131-Z190410-0000	气缸头密封垫	GASKET, CYLINDER HEAD	1	1	
E04-6	12410-Z310110-0000	气缸头盖组合	COVER SUBASSEMBLY, CYLINDER HEAD	1	1	
E04-7	12004-Z080110-0000	气缸头盖密封垫	GASKET, CYLINDER HEAD COVER	1	1	
E04-8	17004-Z100110-0000	废气管	TUBE, BREATHER	1	1	
E04-9	12032-Z080110-0100	缸头盖螺栓	BOLT, CYLINDER HEAD	1	1	
E04-10	12034-Z080110-0099	缸头盖螺栓密封垫+垫片组合	BOLT SUBASSEMBLY, CYLINDER HEAD COVER	1	1	
E04-12	90204-Z100210-0000	双头螺柱	STUD	2	1	
E04-13	90204-Z100320-0000	双头螺柱	STUD	2	1	
E04-14	90502-1220-00	定位销	PIN	2	1	
E04-15	12003-Z080110-0000	缸头螺栓	BOLT, CYLINDER HEAD	4	1	
E04-16	30010-Z010110-0000	火花塞	PLUG, SPARK	1	1	
E04-17	12140-Z190150-0B99	气缸头组合	HEAD SUBASSEMBLY, CYLINDER	1	1	

FIG.2 CRANKCASE. 曲轴箱组件(E17)

图 2 : 曲轴箱组件(E17)

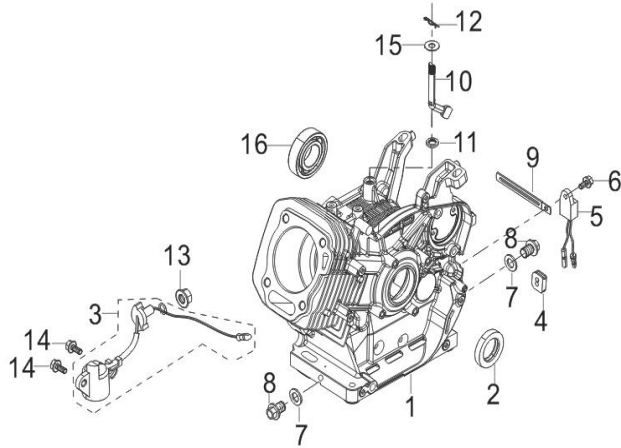

WORK HOURS 工时

- 1、CRANKCASE ASSY.....1.2H
- 2、SEAL, OIL.....1.2H
- 10、ARM, GOVERNOR.....0.9H

REF. NO. 序号	PART NO 物料代码	CHINSES 中文名	DESCRIPTION 英文名	Q'TY 数量	包装数	备注
E17-1	11310-Z220910-0B00	曲轴箱体组合	CRANKCASE SUBASSEMBLY.	1	1	
E17-2	90682-Z310110-0000	油封	SEAL, OIL	1	1	
E17-3	37060-Z080120-0000	机油传感器	SENSOR, ENGINE OIL	1	1	
E17-4	28101-Z080110-0000	橡胶塞	PLUG, RUBBER	1	1	
E17-5	37050-Z010210-0000	机油保护器	PROTECTOR, OIL	1	1	
E17-6	90001-0612-01	六角法兰面螺栓-小系列	BOLT	1	1	
E17-7	90412-Z080110-0000	平垫圈	WASHER, FLAT	2	1	
E17-8	11007-Z080110-0000	放油螺栓	BOLT, DRAIN PLUG	2	1	
E17-9	90684-Z030120-0000	线夹	CLIP	1	1	
E17-10	16061-Z100110-0000	调速臂	ARM, GOVERNOR	1	1	
E17-11	90682-Z100210-0000	油封	SEAL, OIL	1	1	
E17-12	90501-Z010110-0000	开口销	PIN	1	1	
E17-13	90305-Z010210-01	六角法兰面螺母	NUT	1	1	

E17-14	90001-0616-01	六角法兰面螺栓-小系列	BOLT	2	1	
E17-15	90412-Z080210-0000	平垫圈	WASHER, FLAT	1	1	
E17-16	90548-0202-CL	深沟球轴承	BEARING	1	1	

FIG.3 COVER SUBASSEMBLY, CRANKCASE / GEAR ASSY, GOVERNOR(E01)

图 3 : 曲轴箱盖部件 + 调速齿轮部件(E01)

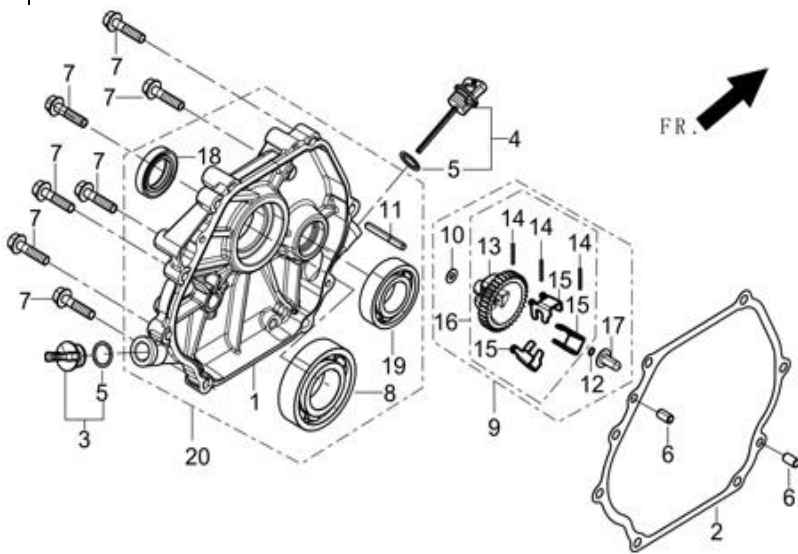

WORK HOURS 工时

- 1、COVER, CRANKCASE.....0.2H
- 2、GASKET, CRANKCASE.....0.2H
- 8/19、BEARING, CRANKSHAFT : REAR.....0.4H
- 18、OIL SEAL, CRANKSHAFT : REAR.....0.3H

REF. NO. 序号	PART NO 物料代码	CHINSES 中文名	DESCRIPTION 英文名	Q'TY 数量	包装数	备注
E01-1	11411-Z100710-0B00	曲轴箱盖	COVER, CRANKCASE	1	1	
E01-2	11001-Z100120-0000	曲轴箱密封垫	GASKET, CRANKCASE	1	1	
E01-3	15030-Z080130-Q500	机油塞组合	PLUG SUBASSEMBLY, ENGINE OIL	1	1	
E01-4	15010-Z080130-Q500	机油尺组合	DIPSTICK SUBASSEMBLY, OIL	1	1	
E01-6	90502-0812-00	定位销-A型	PIN	2	1	
E01-7	90001-0840-01	六角法兰面螺栓-小系列	BOLT	7	1	
E01-8	90547-0207-CL	深沟球轴承	BEARING	1	1	
E01-9	16400-Z100110-0000	调速齿轮部件	GEAR ASSY, GOVERNOR	1	1	

E01-18	90682-Z310110-0000	油封	SEAL, OIL	1	1	
E01-19	90548-0202-CL	深沟球轴承	BEARING	1	1	

FIG.4 ROD,CRANKSHAFT CONNETING 曲柄连杆组件(E03)

图 4 : 曲柄连杆组件(E03)

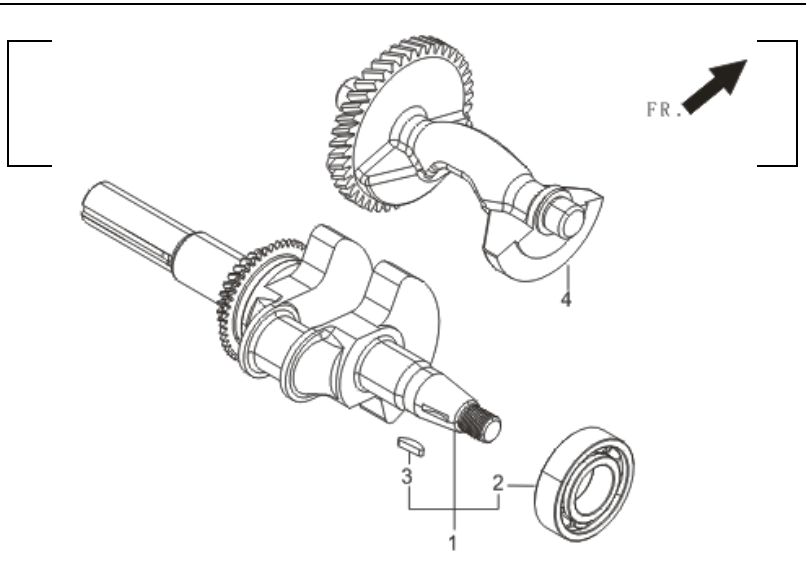

WORK HOURS 工时
1、CRANKSHAFT ASSY.....1.1H

REF. NO. 序号	PART NO 物料代码	CHINSES 中文名	DESCRIPTION 英文名	Q'TY 数量	包装数	备注
E03-1	13300-Z190630-0000	曲轴部件	CRANKSHAFT ASSY.	1	1	
E03-4	13400-Z190320-0000	平衡轴部件	BALANCING SHAFT	1	1	

FIG.5 RING SET,OIL / ROD,CRANKSHAFT CONNETING (E03)

图 5 : 油环组合/曲柄连杆组件 (E03)

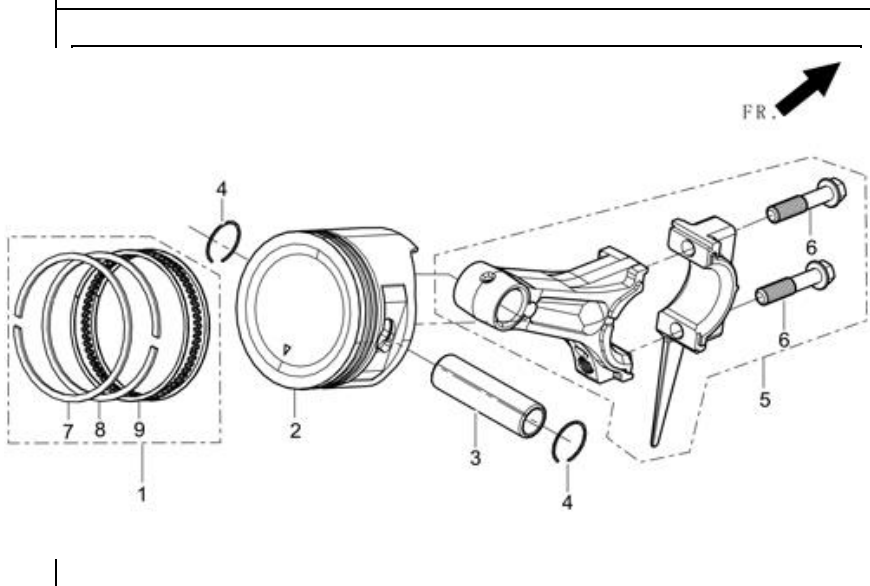

WORK HOURS 工时
1-5、PISTON RINGS SET AND/OR CLIP, PISTON PIN AND/ OR PISTON ASSY. AND/OR PIN, PISTON AND/OR ROD, CONNECTING.....1.1H
INCLUDES : Inspection/Measurement/Cleaning

REF. NO. 序号	PART NO 物料代码	CHINSES 中文名	DESCRIPTION 英文名	Q'TY 数量	包装数	备注
E03-1	13200-Z190110-0000	活塞环部件	PISTON RINGS SET	1	1	
E03-2	13111-Z190110-0000	活塞	PISTON	1	1	
E03-3	13121-Z100110-0000	活塞销	PIN, PISTON	1	1	
E03-4	13122-Z100110-0000	活塞销卡圈	CLIP, PISTON PIN	2	1	
E03-5	13010-Z190120-0000	连杆	ROD, CONNECTING	1	1	

FIG.6 TRAIN,VALVE / CAMSHAFT SUBASSEMBLY (E05)

图 6 : 配气机构组件/凸轮轴 (E05)

REF. NO. 序号	PART NO 物料代码	CHINSES 中文名	DESCRIPTION 英文名	Q'TY 数量	包装数	备注
				WORK HOURS 工时		
				<p>1、CAMSHAFT ASSY.....0.4H INCLUDES:Valve clearance adjustment</p> <p>1、凸轮轴部件.....0.4H</p> <p>4、VALVES SET.....1H 4、气门组件.....1H INCLUDES:Valve clearane adjustment and reface replace intake and exhaust all 0.1 含：气门间隙的调整，且同时换另外个气门时，加 0.1 工时</p> <p>7、ROTATOR,VALVE.....0.2H 7、气门调整帽.....0.2H INCLUDES:Valve clearance adjustment 含：气门间隙调整</p>		
REF. NO. 序号	PART NO 物料代码	CHINSES 中文名	DESCRIPTION 英文名	Q'TY 数量	包装数	备注

REF. NO. 序号	PART NO 物料代码	CHINSES 中文名	DESCRIPTION 英文名	Q'TY 数量	包装数	备注
E08-1	90001-0608-01	六角法兰面螺栓	BOLT	3	1	
E08-2	28200-Z101210-H300	手起动部件	STARTER ASSY, RECOIL	1	1	

FIG.8 SHROUD / SHIELD,LOWER (E14)

图 8 : 缸体导风罩/下护罩 (E14)

	WORK HOURS 工时
	1、SHROUD.....0.2H 1、导风罩.....0.2H 2、SHROUD, CYLINDER BODY.....0.2H 2、缸体导风罩.....0.2H 5、SWITCH SUBASSEMBLY, STOP ENGINE.....0.2H 5、熄火开关组合.....0.2H

REF. NO. 序号	PART NO 物料代码	CHINSES 中文名	DESCRIPTION 英文名	Q'TY 数量	包装数	备注
E14-1	28110-Z310410-H300	导风罩	SHROUD	1	1	
E14-2	19304-Z100210-0000	缸体导风罩	SHROUD, CYLINER BODY	1	1	
E14-3	90001-0612-01	六角法兰面螺栓	BOLT	1	1	
E14-4	90001-0612-01	六角法兰面螺栓	BOLT	5	1	
E14-5	35540-Z060140-Q200	熄火开关组合	SWITCH SUBASSEMBLY, STOP ENGINE	1	1	

FIG.9 CARBURETOR ASSY. (E11)

图 9 : 化油器部件 (E11)

WORK HOURS 工时

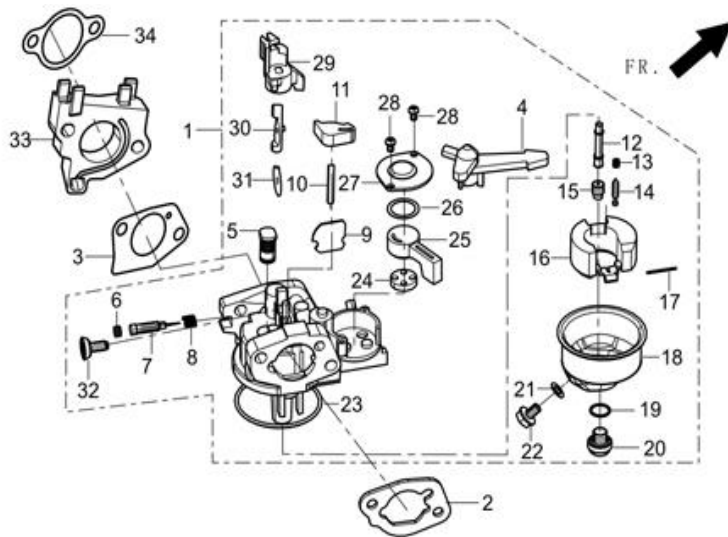

1、CARBURETOR
 ASSY.....0.2H
 ...0.2H
 3/34、GASKET, CARBURETOR
 AND/OR GASKET,
 INLET.....0.2
 H
 33、PLATE, CARBURETOR
 INSULATOR.....0.2H

REF. NO. 序号	PART NO 物料代码	CHINSES 中文名	DESCRIPTION 英文名	Q'TY 数量	包装数	备注
E11-1	16100-Z190910-0000	化油器部件	CARBURETOR ASSY.	1	1	
E11-2	17001-Z080210-0000	空滤器密封垫	GASKET, AIR CLEANER	1	1	
E11-3	16001-Z100110-0000	化油器密封垫	GASKET, CARBURETOR	1	1	
E11-33	16003-Z100110-0000	化油器隔热板	PLATE, CARBURETOR INSULATOR	1	1	
E11-34	17002-Z100110-0000	进气口密封垫	GASKET, CARBURETOR INSULATOR	1	1	

FIG.10 CLEANER, AIR (F02)

图 10 空滤器 (F02)

WORK HOURS 工时

13、CLEANER,
 AIR.....0.1H

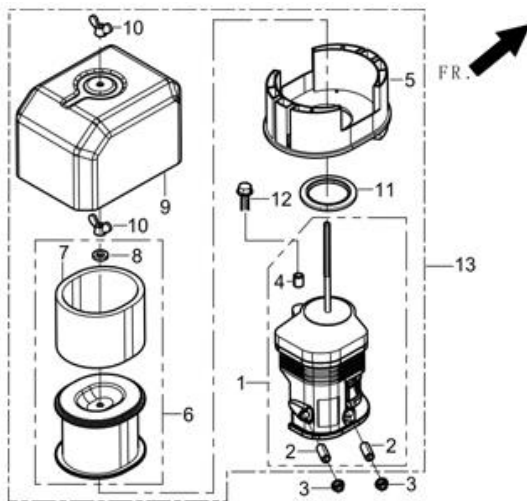

REF. NO. 序号	PART NO 物料代码	CHINSES 中文名	DESCRIPTION 英文名	Q'TY 数量	包装数	备注

F02-3	90305-0600-31	六角法兰面螺母	NUT	2	1	
F02-6	17150-Z100110-0000	空滤器滤芯	ELEMENT SUBASSEMBLY, AIR CLEANER	1	1	
F02-12	90007-0620-A1	六角法兰面螺栓	BOLT	1	1	
F02-13	17100-Z100110-0000	空滤器	CLEANER, AIR	1	1	

FIG.11 MUFFLER ASSY. (F04)

图 11 : 消声器部件 (F04)

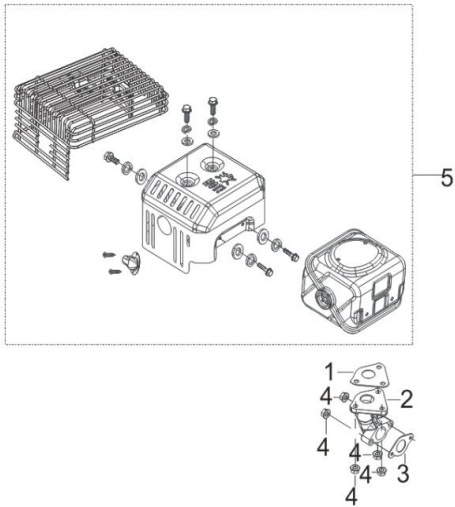

WORK HOURS 工时

3、GASKET, EXHAUST OUTLET.....	0.1H
5、MUFFLER ASSY.....	0.2H

REF. NO. 序号	PART NO 物料代码	CHINSES 中文名	DESCRIPTION 英文名	Q'TY 数量	包装数	备注
F04-1	18101-Z080110-0000	消声器密封垫	BLOCK, MUFFLER SEAT REINFORCING	1	1	
F04-2	18150-Z080210-0000	排气管	PIPE, EXHAUST	1	1	
F04-3	18001-Z190110-0000	排气口密封垫	GASKET, EXHAUST OUTLET	1	1	
F04-4	90305-0800-31	1 型六角螺母	NUT	5	1	
F04-5	18100-Z101710-0002	消声器部件	MUFFLER ASSY.	2	1	

FIG.12 TANK ASSY, FUEL (F01)

图 12 : 油箱部件 (F01)

WORK HOURS 工时

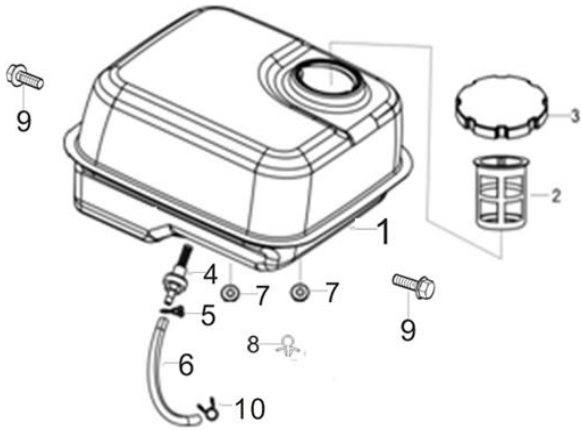

1、TANK,
FUEL.....0.2H
2、STRAINER,
FUEL.....0.1H
6、
TUBE,FUEL.....0.1
H

REF. NO. 序号	PART NO 物料代码	CHINSES 中文名	DESCRIPTION 英文名	Q'TY 数量	包装数	备注
F01-1	16620-Z310110-H300	油箱	TANK, FUEL	1	1	
F01-2	16652-Z010610-0000	燃油滤网	STRAINER, FUEL	1	1	
F01-3	16730-Z300120-0000	油箱盖	COVER, FUEL TANK	1	1	
F01-4	16680-Z010110-0000	出油嘴组合	OUTLET SUBASSEMBLY, FUEL TANK OIL	1	1	
F01-5	90740-Z010210-0000	卡箍	COLLAR	1	1	
F01-6	90686-Z080910-0000	油管	TUBE, FUEL	1	1	
F01-7	90305-0800-31	六角法兰面螺母	NUT	2	1	
F01-8	90684-Z080110-0000	线夹	CLIP	1	1	
F01-9	90001-0825-01	六角法兰面螺栓-小系列	BOLT	2	1	
F01-10	90740-Z010210-0000	卡箍	COLLAR	1	1	

FIG.13 FLYWHEEL / IMPELLER / STARTER PULLEY / IGNITION COIL (E15)

图 13 : 飞轮/叶轮/启动杯/点火线圈 (E15)

WORK HOURS 工时

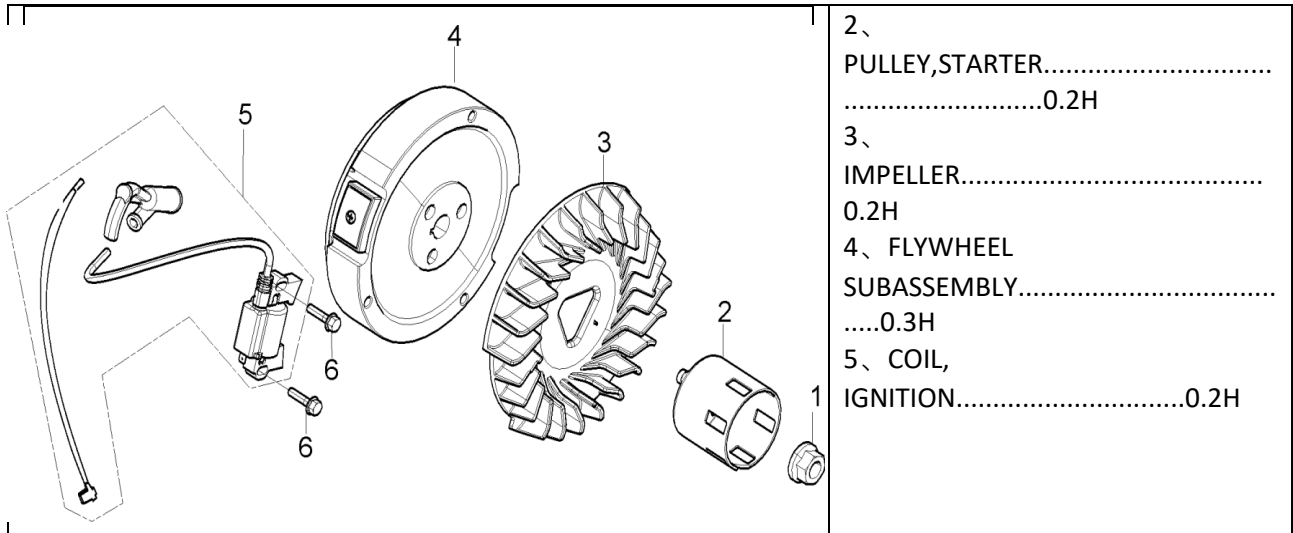

- 2、PULLEY,STARTER.....0.2H
- 3、IMPELLER.....0.2H
- 4、 FLYWHEEL SUBASSEMBLY.....0.3H
- 5、 COIL, IGNITION.....0.2H

REF. NO. 序号	PART NO 物料代码	CHINSES 中文名	DESCRIPTION 英文名	Q'TY 数量	包装数	备注
E15-1	13501-Z080110-0000	飞轮螺母	NUT, FLYWHEEL	1	1	
E15-2	28002-Z100210-0000	起动杯	PULLEY,STARTER	1	1	
E15-3	19352-Z100120-0000	叶轮	IMPELLER	1	1	
E15-4	13510-Z220110-0000	飞轮组合	FLYWHEEL SUBASSEMBLY	1	1	
E15-5	30400-Z190210-0100	点火线圈	COIL, IGNITION	1	1	
E15-6	90001-0628-01	六角法兰面螺栓-小系列	BOLT	2	1	

FIG.14 CONTROL ASSY, THROTTLE (E13)

图 14 : 油门操纵部件 (E13)

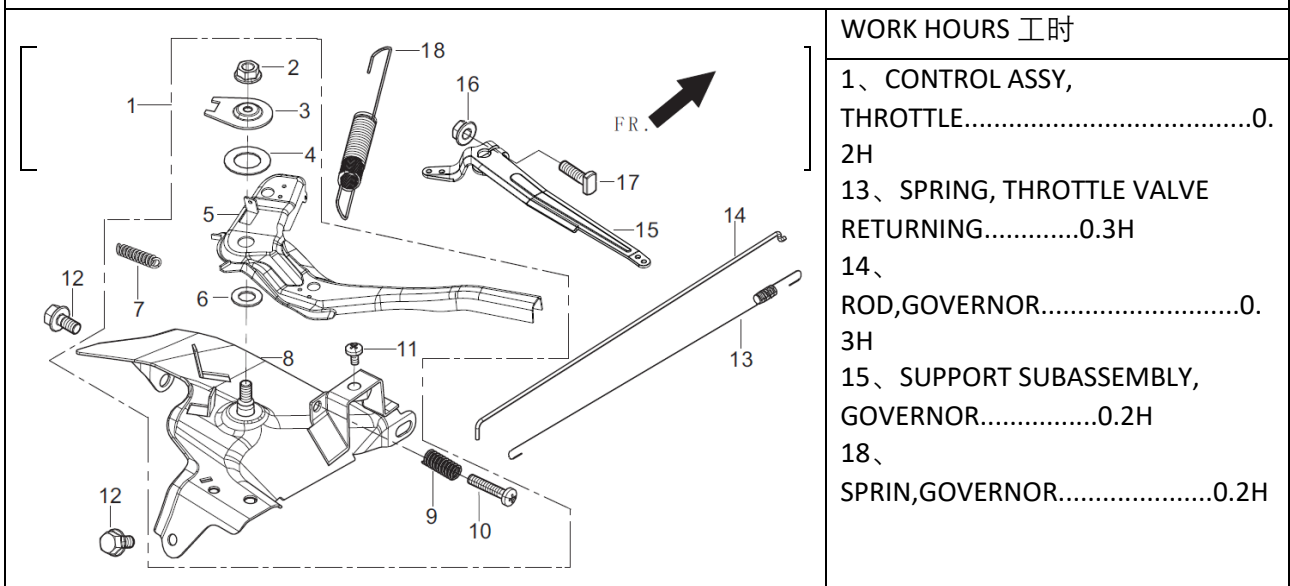

- WORK HOURS 工时
- 1、 CONTROL ASSY, THROTTLE.....0.2H
 - 13、 SPRING, THROTTLE VALVE RETURNING.....0.3H
 - 14、 ROD,GOVERNOR.....0.3H
 - 15、 SUPPORT SUBASSEMBLY, GOVERNOR.....0.2H
 - 18、 SPRIN,GOVERNOR.....0.2H

REF. NO. 序号	PART NO 物料代码	CHINSES 中文名	DESCRIPTION 英文名	Q'TY 数量	包装数	备注
E13-1	16520-Z100710-0000	油门操纵组合	CONTROL SUBASSEMBLY, THROTTLE	1	1	
E13-12	90001-0612-01	六角法兰面螺栓	BOLT	2	1	
E13-13	16012-Z080110-0000	节气门复位弹簧	SPRING, THROTTLE VALVE RETURNING	1	1	
E13-14	16062-Z100110-0000	调速拉杆	ROD, GOVERNER	1	1	
E13-15	16070-Z100120-0000	调速支架组合	SUPPORT SUBASSEMBLY, GOVERNOR	1	1	
E13-16	90305-0600-31	六角法兰面螺母	NUT	1	1	
E13-17	16072-Z010110-0000	调速支架固定螺栓	BOLT, GOVERNOR SUPPORT	1	1	
E13-18	16063-Z100710-0000	调速弹簧	SPRING, GOVERNOR	1	1	